

ISOMETRIC VIEW

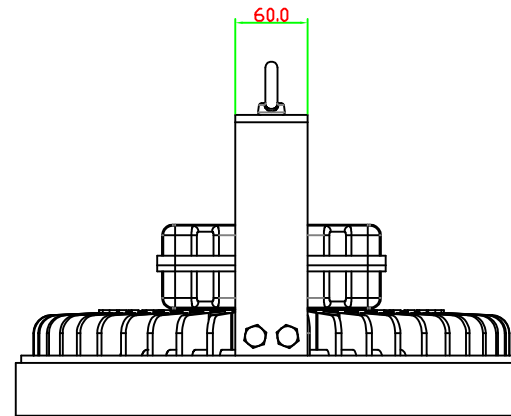
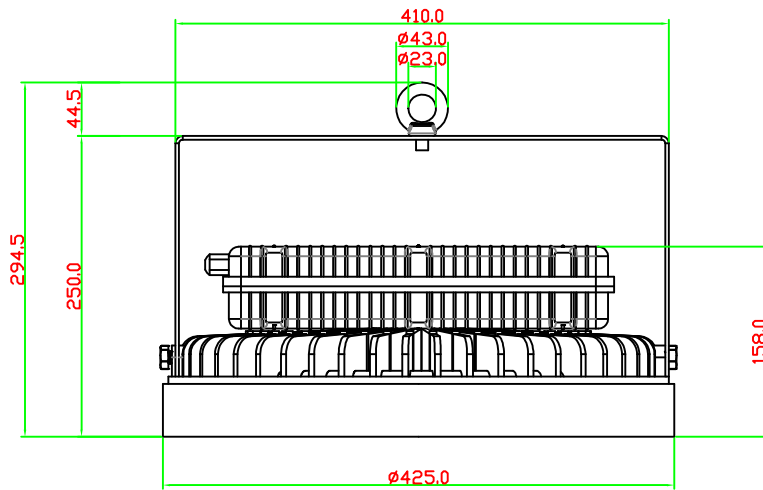

GA DRAWING

NOTES :---

- 1) ALL DIMENSIONS ARE IN mm.
- 2) ALL CORNER'S ARE FILLETED
- 3) MATERIAL : Aluminium Die casting (LM-6)
- 4) HARDNESS :
- 5) NET WEIGHT : 10.8 Kg

MOD. NO.	DETAILS OF MODIFICATION	DATE	CHD.	APPRD.

UNSPECIFIED TOLERANCE IS: 2102			
RANGE	FINE	MEDIUM	COORSE
0.5 TO 6	±0.05	±0.1	±0.2
6 TO 30	±0.1	±0.2	±0.5
30 TO 120	±0.15	±0.3	±0.8
120 TO 325	±0.2	±0.5	±1.2
325 TO 1000	±0.3	±0.8	±2
1000 TO 2000	±0.5	±1.2	±3

DATE	10/11/2020
DRN.	GANESH
CHD.	
APRD.	

Eetamax
Energy Solutions Pvt. Ltd. I-141, MIDC Ahmednagar.

SCALE	1 : 1
-------	-------

PART DESCRIPTION :
MODEL : Eetamax Avira Bay Light 300W
DRG. NO. :